

GESTRA thermostatic steam trap

with membrane regulator, up to PN 40



Rhombic cover

Easy in-line maintenance.
Flange connecting bolts can be inserted into the flange holes from the trap side.

Thermostatic capsule

A regulating element that can easily be exchanged without removing the body. Precise reaction to any temperature change. Corrugated membrane of Hastelloy®.
High elasticity.
Long service life.

Tandem shut-off

Seat unaffected by dirt, with double shut-off.

Metallic base bushing

Recessed cover gasket

Connections

Flanges, screwed sockets, socket-weld or butt-weld ends.

Non-return valve action

with hollow cone for low mass
Quick closure in reaction to waterhammer.

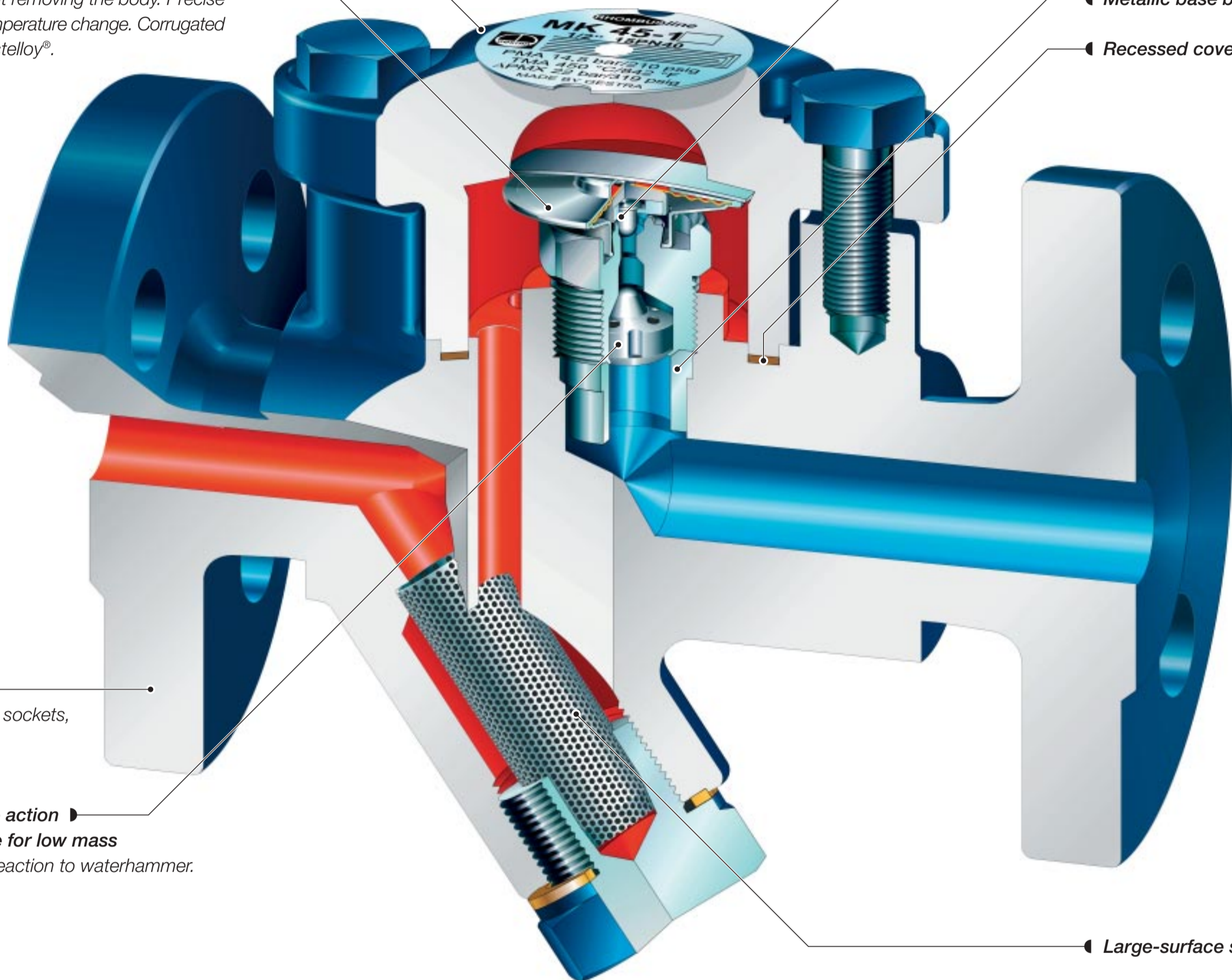

Large-surface strainer



Shown here: MK 45-1, PN 40

With Energy into the Future

Functional principle

Thermostatic capsule

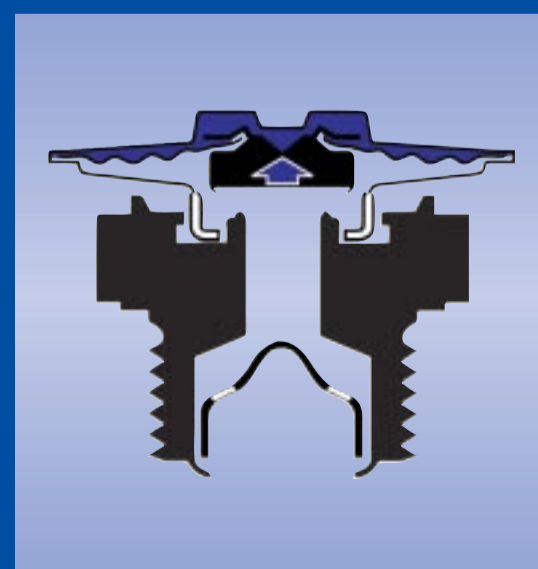

Opening:
The thermostatic capsule contains a liquid filling, the evaporation temperature of which is slightly lower than that of the water. When the plant has been shut down, or if the condensate is cold, the liquid filling is completely in the liquid state, owing to the low ambient temperature. The internal pressure of the thermostatic capsule is lower than the surrounding pressure (service pressure), so that the membrane presses the valve towards the open position.

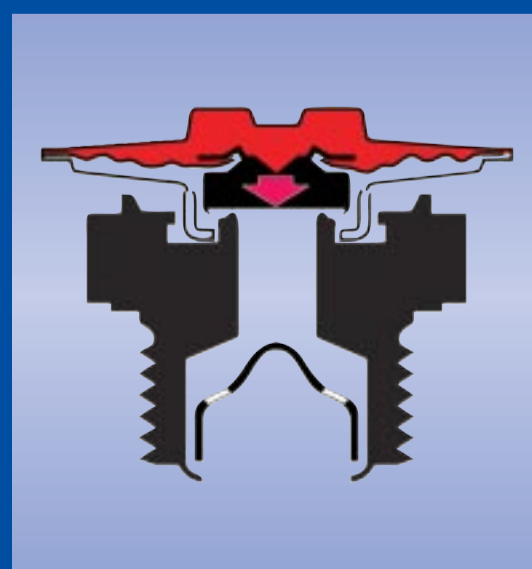

Closing:
With increasing temperature of the condensate, the liquid filling begins to evaporate. The pressure in the thermostatic capsule then rises. The membrane presses the valve towards the closed position, which is reached shortly before the temperature attains the boiling point of the condensate.

Tandem shut-off

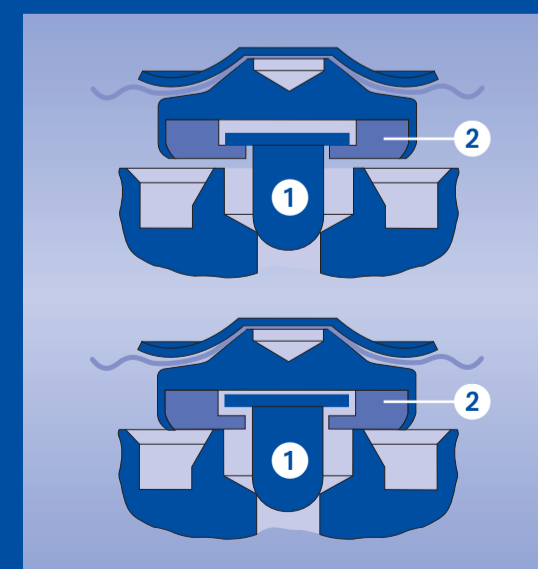

The self-centring valve cone (1) ensures a steam-tight closure. With increasing temperature, the downstream single seat (2) follows, offering a further guarantee of tightness, even in the case of dirt accumulation. Through the twofold pressure drop, wear is reduced and the service life extended.

Top: during operation
Seating surface 1 closed
(regulator moves to closed position)

Bottom: Steam trap closed
Both seating surfaces closed

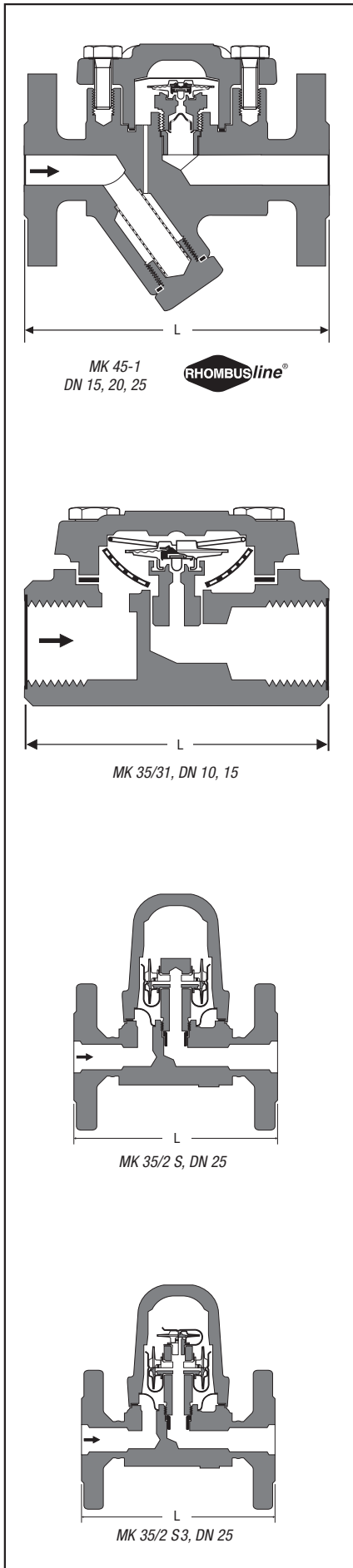

Features of the MK series

- Very sensitive response characteristic
- Function is not impaired by high back pressure
- Automatic air-venting (trap can be used for thermal air-venting in steam systems)
- Installation in any position (horizontal and vertical lines)
- High hot-water capacities even with low differential pressures
- With tandem seat (double sealing) for low condensate flowrates
- Built-in non-return valve
- Stainless steel internals (corrugated membrane of Hastelloy)
- Design "U" with undercooling capsule: utilization of a certain amount of sensible heat by banking-up of condensate, decreasing the amount of flash steam
- Optional extra: Integrated condensate monitoring for MK 45 (temperature or steam loss)

Specification

Type	Design/Application
MK 45-1 MK 35/31 ¹⁾	With tandem seat (double sealing) For low condensate flowrates, steam-tracing, steam-line drainage, air-venting
MK 45-2 MK 35/32 ¹⁾	With single seat For medium condensate flowrates, steam-tracing, drainage of heat exchangers, air-venting
MK 25/2 ¹⁾ MK 25/2 S ¹⁾ MK 35/2 S ¹⁾ MK 35/2 S3 ¹⁾	With single seat For large condensate flowrates, drainage of heat exchangers
MK 36/51 ¹⁾ MK 36/52 ¹⁾	With tandem seat (double sealing) – with flat gasket For small/large condensate flowrates, steam tracing, steam-line drainage, venting and vacuum-breaking. Also suitable for food, biological and pharmaceutical applications.
MK 45 A-1 MK 45 A-2	For small and large condensate flowrates; steam-tracing, steam-line drainage, air-venting

¹⁾ Can also be used for vacuum breaking (aerating).

Air Venting

Steam Trap for Thermostatic Air-Venting with Membrane Regulator

The thermostatic steam traps with membrane regulators of the MK series can also be used for air-venting.

Application

Thermostatic steam trap for automatic air-venting and discharge of non-condensable gases and steam/air mixtures from steam lines and heat exchangers.

A special type of membrane might be required.

Pressure/Temperature Ratings ^{*})

Type	PN	Δ PMX [bar]	Material		Max. Pressure/Temp. Rating	
			EN	ASTM	PMA / TMA	PMA / TMA
MK 35/31	PN 25	21	P 250 GH ¹⁾	A 105 ¹⁾	18.6 bar / 225 °C	14.4 bar / 400 °C
MK 35/32	PN 25	21	P 250 GH ¹⁾	A 105 ¹⁾	18.6 bar / 225 °C	14.4 bar / 400 °C
MK 45-1	PN 40	22	P 250 GH ¹⁾	A 105 ¹⁾	28.4 bar / 250 °C	23.1 bar / 400 °C
MK 45-2	PN 40	22	P 250 GH ¹⁾	A 105 ¹⁾	28.4 bar / 250 °C	23.1 bar / 400 °C
MK 35/2 S DN 25	PN 40	22	P 250 GH	A 105 ³⁾	28.4 bar / 250 °C	23.1 bar / 400 °C
MK 35/2 S3 DN 25	PN 40	22	P 250 GH	A 105 ³⁾	28.4 bar / 250 °C	23.1 bar / 400 °C
MK 25/2 DN 40/50	PN 40	22	P 250 GH	A 105 ³⁾	28.4 bar / 250 °C	23.1 bar / 400 °C
MK 25/2 S DN 40/50	PN 40	22	P 250 GH ²⁾	A 105 ³⁾	28.4 bar / 250 °C	23.1 bar / 400 °C
MK 36/51, MK 36/52	–	32	1.4301 ⁴⁾	A 182 F304	32 bar / 240 °C	32 bar / 240 °C
MK 45 A-1	PN 40	22	1.4404 ¹⁾	A 182 F316 L ¹⁾	29.3 bar / 200 °C	24 bar / 400 °C
MK 45 A-2	PN 40	22	1.4404 ¹⁾	A 182 F316 L ¹⁾	29.3 bar / 200 °C	24 bar / 400 °C

¹⁾ Material complies with EN and ASTM requirements.

²⁾ MK 25/2 S DN 40/50: cover made of cast steel GS-C 25 (ASTM nearest equivalent: A 216 Gr. WCB)

³⁾ Physical and chemical properties comply with EN grade. ASTM nearest equivalent grade is stated for guidance only.

⁴⁾ EN nearest equivalent grade is stated for guidance only.

^{*}) For more information see data sheet.

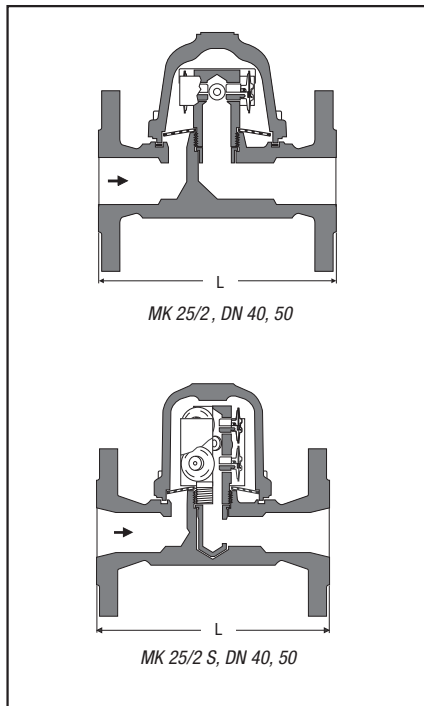

Available End Connections and Overall Length

Type	Connection	Overall length (L) in mm						
		DN 8 1/4"	DN 10 3/8"	DN 15 1/2"	DN 20 3/4"	DN 25 1"	DN 40 1 1/2"	DN 50 2"
MK 45-1	Flanged DIN PN 40	–	–	150	150	160	–	–
MK 45-2	Flanged ASME 150 ¹⁾	–	–	150	150	160	–	–
MK 45 A-1	Flanged ASME 300 ¹⁾	–	–	150	150	160	–	–
MK 45 A-2	Screwed sockets	–	–	95	95	95	–	–
MK 35/2 S3 only DN 25	Socket-weld (SW)	–	–	95	95	95	–	–
MK 35/2 S only DN 25	Butt-weld (BW) ²⁾	–	–	200	200	200	–	–
MK 35/31	Screwed sockets	–	70	70	–	–	–	–
MK 35/32	Socket-weld (SW)	–	–	95	–	–	–	–
MK 25/2 DN 40 – 50	Flanged DIN PN 40	–	–	–	–	–	230	230
MK 25/2 S DN 40 – 50	Flanged ASME 150	–	–	–	–	–	230	230
	Flanged ASME 300	–	–	–	–	–	230	230
	Screwed sockets	–	–	–	–	–	130	230
	Socket-weld (SW)	–	–	–	–	–	130	230
MK 36/51	Screwed sockets	65	65	65	65	–	–	–
MK 36/52	Union butt-weld nipples ³⁾	–	–	150	–	–	–	–
	Hinged clamp	–	65	65	65	65	–	–

STAINLESS
STEEL

- 1) MK 45 with ASME flanges: overall length 172 mm available on request.
- 2) Only MK 45
- 3) Made of carbon steel or stainless steel

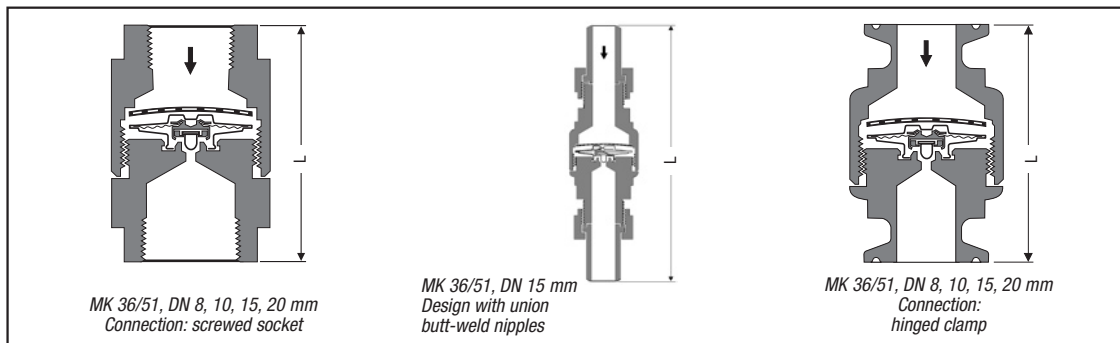

Capacity Charts

The charts show the maximum hot condensate capacities.

- MK 45-1** (Curve 1) **MK 35/31** (Curve 1)
- MK 45-2** (Curve 2) **MK 35/32** (Curve 2)
- MK 36/51** (Curve 3) **MK 36/52** (Curve 2)
- MK 25/2 S, DN 40, 50** (Curve 1) **MK 35/2 S3, DN 25** (Curve 3)
- MK 25/2, DN 40, 50** (Curve 2) **MK 35/2S, DN 25** (Curve 4)

