

GESTRA steam trap with ball float

UNA 1 range, up to PN 40

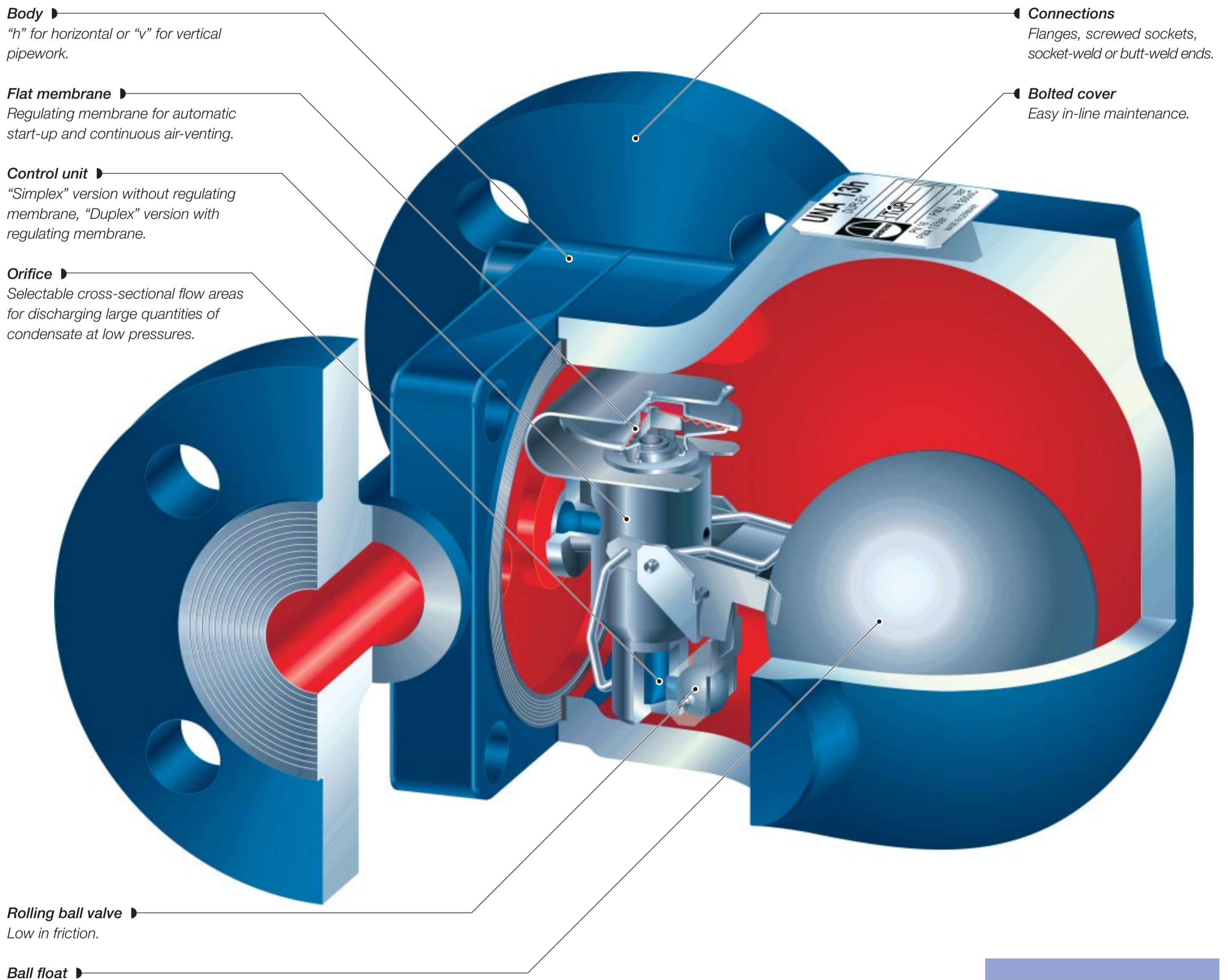

With Energy into the Future

Functional principle

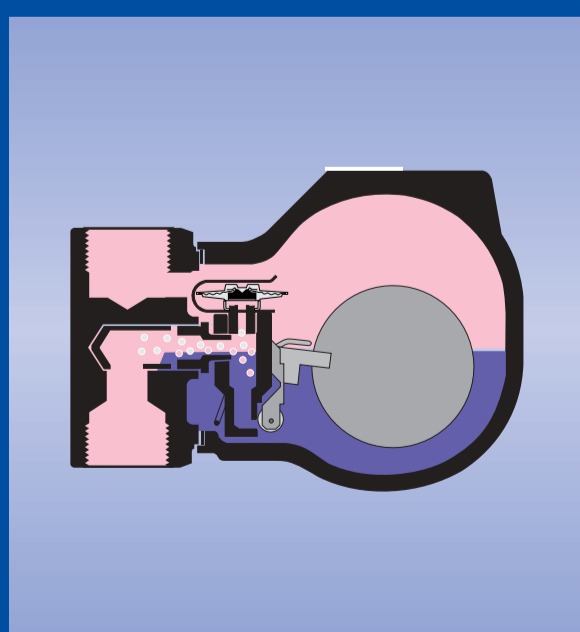

Automatic thermostatic air-venting by regulating membrane. Cold condensate and air are discharged.

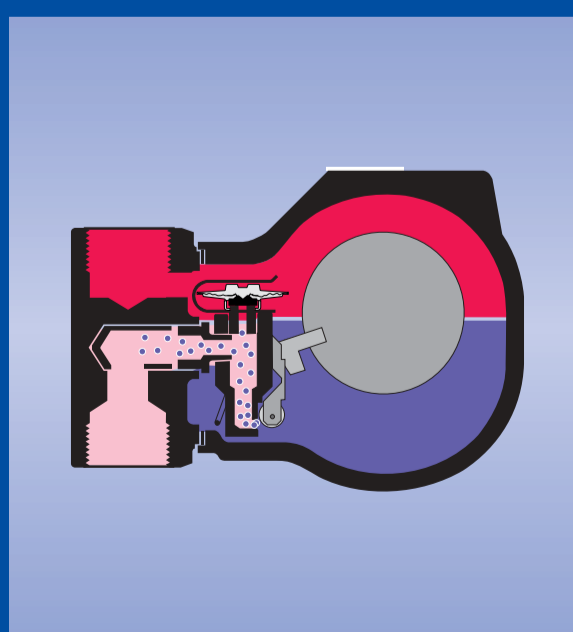

The rolling ball valve is actuated directly by the float as a function of the condensate flowrate.

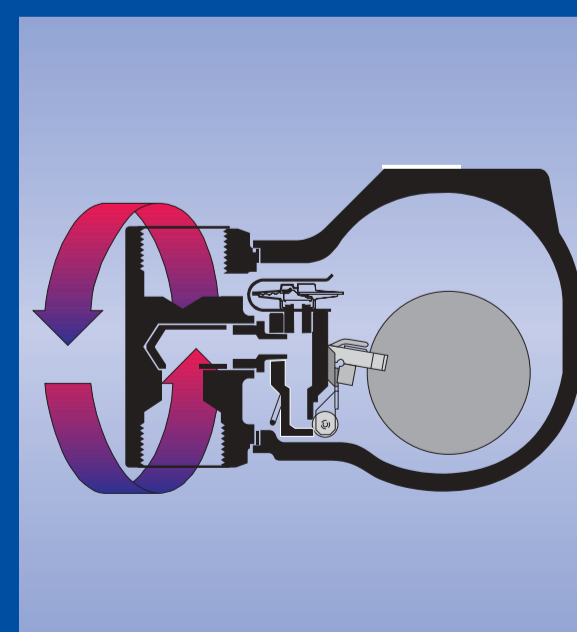

By moving the body, the trap can be adapted to the pipework (horizontal or vertical) in the direction of flow (left-to-right or right-to-left).