

# Model S206-PG / S206-PG\*

\*Single Rolling Diaphragm

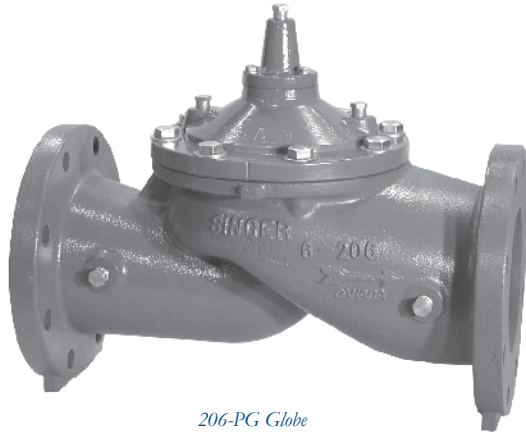

## Reduced Port, Single Chamber Hydraulically Operated Valve



206-PG Globe

The Singer Model 206-PG Control Valve is hydraulically operated by introducing or releasing water from the control chamber above the diaphragm / inner valve assembly. The preferred choice for relief valves, flow control and applications of lower to medium flows.

The Model 206-PG is usually combined with Singer specific purpose pilots and accessories to provide control for a wide range of functions: typically controlling pressure, flow or level, either singly or in almost limitless combinations to suit particular applications. Basic valve options greatly extend the range of application. (See Main Valve Options, High-Performance, Standard Models, and Pilots & Accessories Sections).

Option



206-PG Angle

- GLOBE AND ANGLE STYLE
- SUPERIOR LOW FLOW CHARACTERISTICS
- STABLE LOW FLOW
- EVERY VALVE FACTORY TESTED

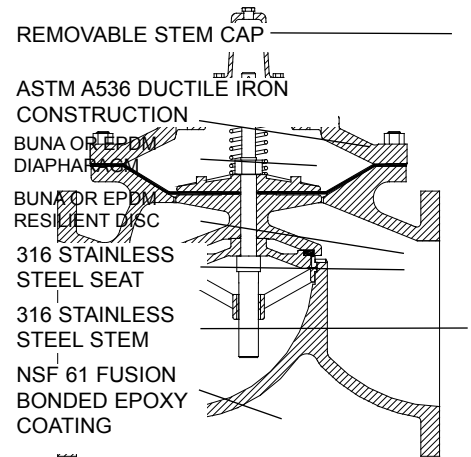

### When Ordering Please Specify

1. Catalog Model #
2. Globe or Angle Pattern
3. End Connections
4. Valve Size

### Valve Sizes & Materials:

Valve Materials		
	Standard	Optional
<b>Ductile</b>		
<b>Available Sizes</b>	Flanged	
Globe	3" to 36" (80-900mm)	
Angle	4" to 8" (100-200mm)	
<b>Valve Components</b>		
1. Valve Body, Cover	ASTMA 536 - 65/45/12 Ductile Iron	
2. Seat Ring*	AISI 316 Stainless Steel	
3. Disc Retainer	B62 Bronze / A48 or A536 Ductile Iron	AISI 316 Stainless Steel
4. Stem	AISI 316 Stainless Steel	
5. Stem Nut	B16 Brass	AISI 316 Stainless Steel
6. Spring	316 Stainless Steel	316 Stainless Steel
7. Guide Bushings*	B16 Brass or SAE 660 Bronze	AISI 316 Stainless Steel
8. Diaphragm	EPDM / Buna-N	EPDM / Buna-N / Viton (limited sizes)
9. Resilient Disc	EPDM	Buna / Viton (limited sizes)
10. Coating	NSF61 Approved Fusion Bonded Epoxy	
11. Fasteners	AISI 18-8 Stainless Steel	AISI 316 Stainless Steel

\*Seat Ring & Bottom Guide 1-piece combination: 316 Stainless Steel standard: 206-PG, 3 in / 80 mm – 10 in / 250 mm (see 106-PG section)

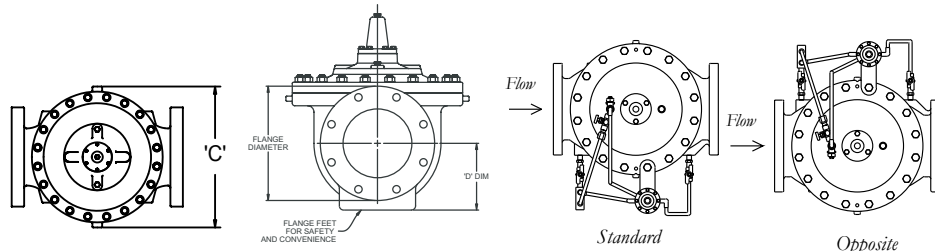
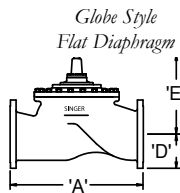

See Pilot System Information Below

ANSI Valve Data (US Units) / see following page for additional data:

Size	DWG	Standard	Flat Diaphragm System				
			3"	4"	6"	8"	10"
Inches	REF	ANSI	All figures show in inches unless otherwise stated				
<b>Globe Dimensions</b>							
Lay Length	A	NPT	-	-	-	-	-
Centerline to Bottom	D	NPT	-	-	-	-	-
Lay Length	A	150F	12.00	15.00	20.13	25.00	24.50
Centerline to Bottom	D	150F	4.00	4.60	5.62	6.75	8.00
Lay Length	A	300F	-	15.63	21.00	26.00	25.88
Centerline to Bottom	D	300F	-	5.00	6.34	7.50	8.63
<b>Angle Dimensions</b>							
Center Inlet to Discharge	B	NPT	-	-	-	-	-
Center Discharge to Inlet	F	NPT	-	-	-	-	-
Center Inlet to Discharge	B	150F	-	7.56	10.19	12.50	-
Center Discharge to Inlet	F	150F	-	5.94	6.19	9.00	-
Center Inlet to Discharge	B	300F	-	7.88	10.63	13.00	-
Center Discharge to Inlet	F	300F	-	6.25	6.81	9.50	-
<b>Common Dimensions (Globe and Angle)</b>							
Width	C		8.19	10.00	12.50	16.00	20.00
Height (To Stem Cap) Globe	E		7.50	9.62	10.50	14.13	18.63
Height (To Stem Cap) Angle	E		-	7.75	8.82	11.30	-
Body Port Tapping		FNPT	3/8	3/8	3/8	3/8	1/2
Stem Cap Plug		MNPT	3/8	3/8	3/8	3/8	3/8
Cover Port Tapping		FNPT	3/8	3/8	3/8	1/2	1/2
Valve Stroke			9/16	1 1/8	1 7/16	1 11/16	2 7/8
Displaced Bonnet Volume (Gallons)			0.02	0.09	0.20	0.56	1.67
Approx. Shipping Weight (Lbs.)			75	100	250	500	650
<b>Capacities (USPGM) Globe &amp; Angle</b>							
CV - Globe			60	150	250	505	985
CV - Angle			-	150	250	560	-
Continuous (Globe)			300	580	1025	2300	4100
Intermittent (Globe)			373	690	1190	2700	4670
Momentary (Globe)			564	1236	2160	4800	8400
<b>Maximum Pressure Ratings</b>							
PSI*		FNPT	-	-	-	-	-
PSI		150F	250	250	250	250	250
PSI*		300F	400	400	400	400	400
* Valves rated and stamped 400 psi. Valves rated and stamped 600 psi on request.							
<b>Maximum Temperature</b>							
Fahrenheit			180°	180°	180°	180°	180°

NOTES:

- Drilled as per ANSI B16.42.
- Class 150 machined flat faced | Class 300 machined raised faced.
- Castings are based on ANSI Class 150 or Class 300 standards.
- Consult the factory if working pressure exceeds 300 psi.

Add a minimum 6" (150mm) on one side, for Pilot System. Pilot system is installed as "standard" ("opposite" please specify). Dimensions are nominal. Allow 1/8" (3mm) for machining tolerance. Allow one to three feet for installation and maintenance clearances. Consult factory for certified dimensions. Install with stem vertical is preferred, 10" (250mm) and larger is mandatory.

# Model S206-PG / 206-PG\* \*Single Rolling Diaphragm



Angle Style  
Rolling Diaphragm

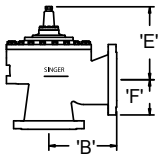

Globe Style  
Rolling Diaphragm

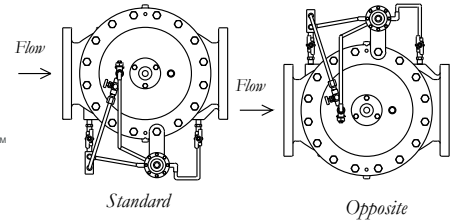
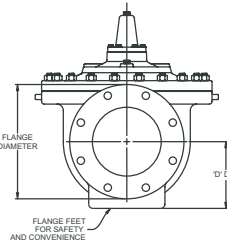
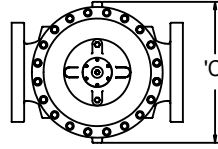
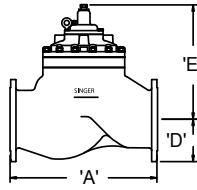

See Pilot System Information Below

## ANSI Valve Data (US Units) / see previous page for additional data:

Size	DWG	Standard	Rolling Diaphragm System							
Inches	REF	ANSI	12"	16"	18"	20"	24" x 16"	24" x 20"	30"	36"
All figures shown in inches unless otherwise stated.										
<b>Globe Dimensions</b>										
Lay Length	A	NPT	-	-	-	-	-	-	-	-
Centerline to Bottom	D	NPT	-	-	-	-	-	-	-	-
Lay Length	A	150F	27.50	36.00	42.00	45.00	50.50	61.50	69.93	69.93
Centerline to Bottom	D	150F	9.50	11.75	12.50	13.75	16.50	17.13	20.68	23.75
Lay Length	A	300F	29.00	37.63	43.63	46.63	52.25	63.25	-	-
Centerline to Bottom	D	300F	10.25	12.75	14.00	15.25	18.00	19.65	-	-
<b>Angle Dimensions</b>										
Center Inlet to Discharge	B	NPT	-	-	-	-	-	-	-	-
Center Discharge to Inlet	F	NPT	-	-	-	-	-	-	-	-
Center Inlet to Discharge	B	150F	-	-	-	-	-	-	-	-
Center Discharge to Inlet	F	150F	-	-	-	-	-	-	-	-
Center Inlet to Discharge	B	300F	-	-	-	-	-	-	-	-
Center Discharge to Inlet	F	300F	-	-	-	-	-	-	-	-
<b>Common Dimensions (Globe and Angle)</b>										
Width	C		22.13	26.00	30.31	31.50	36.00	36.00	49.75	49.75
Height (To Stem Cap) Globe	E		23.31	26.75	31.38	31.38	31.38	34.46	45.75	45.75
Height (To Stem Cap) Angle	E		-	-	-	-	-	-	-	-
Body Port Tapping		FNPT	3/4	3/4	3/4	3/4	3/4	3/4	3/4	3/4
Stem Cap Plug		MNPT	3/4	3/4	3/4	3/4	3/4	3/4	3/4	3/4
Cover Port Tapping		FNPT	3/4	3/4	3/4	3/4	3/4	3/4	3/4	3/4
Valve Stroke			3 1/4	3 3/4	4 3/4	4 3/4	4 3/4	5 9/16	6	6
Displaced Bonnet Volume (Gallons)			1.50	2.30	6.75	6.75	6.75	11.73	14.75	14.75
Approx. Shipping Weight (Lbs.)			900	1400	2400	2600	2800	4500	6200	7000
<b>Capacities (USPGM) Globe &amp; Angle</b>										
CV - Globe			1550	2200	3300	3400	3500	6150	7800	8000
CV - Angle			-	-	-	-	-	-	-	-
Continuous (Globe)			6400	9230	16500	16500	16500	17400	33650	33800
Intermittent (Globe)			7320	10470	20915	20915	20915	21700	37490	37640
Momentary (Globe)			13200	19200	30000	30050	30100	39000	67490	67640
<b>Maximum Pressure Ratings</b>										
PSI*		FNPT	-	-	-	-	-	-	-	-
PSI		150F	250	250	250	250	250	250	250	250
PSI*		300F	400	400	400	400	400	400	400	400
* Valves rated and stamped 400 psi as standard. Valves rated and stamped 600 psi on request.										
<b>Maximum Temperature</b>										
Fahrenheit			180°	180°	180°	180°	180°	180°	180°	180°

### NOTES:

- Drilled as per ANSI B16.42.
- Class 150 machined flat faced | Class 300 machined raised faced.
- Castings are based on ANSI Class 150 or Class 300 standards.
- Consult the factory if working pressure exceeds 300 psi.

Add a minimum 6" (150mm) on one side, for Pilot System. Pilot system is installed as "standard" ("opposite" please specify). Dimensions are nominal. Allow 1/8" (3mm) for machining tolerance. Allow one to three feet for installation and maintenance clearances. Consult factory for certified dimensions. Install with stem vertical is preferred, 10" (250mm) and larger is mandatory.

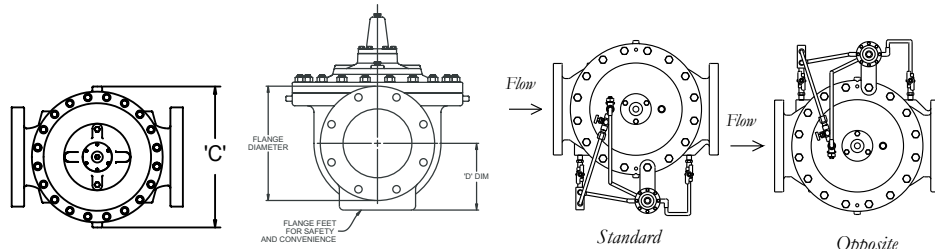
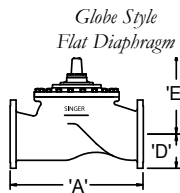

See Pilot System Information Below

ANSI Valve Data (Metric Units) / see following page for additional data:

Size	DWG	Standard	Flat Diaphragm System				
MM	REF	ANSI	80	100	150	200	250
<b>All figures show in mm unless otherwise stated</b>							
<b>Globe Dimensions</b>							
Lay Length	A	FNPT	-	-	-	-	-
Centerline to Bottom	D	FNPT	-	-	-	-	-
Lay Length	A	150F	305	381	511	635	622
Centerline to Bottom	D	150F	102	117	143	171	203
Lay Length	A	300F	-	397	533	660	657
Centerline to Bottom	D	300F	-	127	161	191	219
<b>Angle Dimensions</b>							
Center Inlet to Discharge	B	FNPT	-	-	-	-	-
Center Discharge to Inlet	F	FNPT	-	-	-	-	-
Center Inlet to Discharge	B	150F	-	192	259	318	-
Center Discharge to Inlet	F	150F	-	151	157	229	-
Center Inlet to Discharge	B	300F	-	200	270	330	-
Center Discharge to Inlet	F	300F	-	159	173	241	-
<b>Common Dimensions (Globe and Angle)</b>							
Width	C		208	254	318	406	508
Height (To Stem Cap) Globe	E		191	244	267	359	473
Height (To Stem Cap) Angle	E		-	197	224	287	-
Body Port Tapping	FNPT	Inches	3/8	3/8	3/8	3/8	1/2
Stem Cap Plug	MNPT	Inches	3/8	3/8	3/8	3/8	3/8
Cover Port Tapping	FNPT	Inches	3/8	3/8	3/8	1/2	1/2
Valve Stroke		mm	14	29	37	43	73
Displaced Bonnet Volume (Litres)			0.08	0.34	0.76	2.12	6.31
Approx. Shipping Weight (Kilograms)			34	45	113	227	295
<b>Capacities (L/s) Globe &amp; Angle</b>							
CV - Globe			1.4	3.6	6.0	12.0	23.6
CV - Angle			-	3.6	5.9	13.3	-
Continuous (Globe)			18.9	36.6	64.7	145.1	258.7
Intermittent (Globe)			23.5	43.5	75.1	170.3	294.6
Momentary (Globe)			35.6	78.0	136.3	302.8	530.0
<b>Maximum Pressure Ratings</b>							
Bar	FNPT		-	-	-	-	-
Bar	150F		17	17	17	17	17
Bar*	300F		27.6	27.6	27.6	27.6	27.6
* Valves rated and stamped 27.6 bar as standard. Valves rated and stamped 41 bar on request.							
<b>Maximum Temperature</b>							
Celsius			82°	82°	82°	82°	82°

**NOTES:**

- Castings are based on ANSI Class 150 or Class 300 standards.
- Ansi Flanges drilled to ISO 2531/BS54504 PN 10, 16, 25, or 40, or threaded BSPT.
- Consult the factory if working pressure exceeds 20 Bar

Allow a minimum of 6" (150mm) on one side, for **Pilot System**. Pilot system is installed as "standard" ("Opposite" - please specify). Dimensions are nominal. Allow 1/8" (3mm) for machining tolerance. Allow 1-3 feet (1/3 to 1 meter) for installation and maintenance clearances. Consult factory for certified dimensions. Install with stem vertical is preferred, 12"(300mm) and larger is mandatory.

# Model S206-PG / 206-PG\* \*Single Rolling Diaphragm



Angle Style  
Rolling Diaphragm

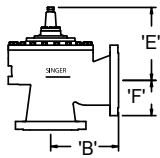

Globe Style  
Rolling Diaphragm

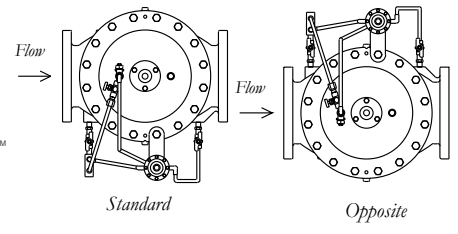
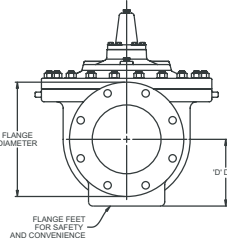
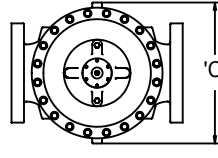
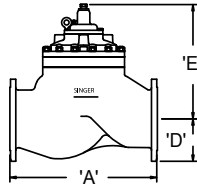

See Pilot System Information Below

## ANSI Valve Data (Metric Units) / see previous page for additional data:

Size	DWG	Standard	Rolling Diaphragm System							
MM	REF	ANSI	300	400	450	500	600 x 400	600 x 500	700	900
All figures shown in mm unless otherwise stated.										
<b>Globe Dimensions</b>										
Lay Length	A	FNPT	-	-	-	-	-	-	-	-
Centerline to Bottom	D	FNPT	-	-	-	-	-	-	-	-
Lay Length	A	150F	699	914	1067	1143	1283	1562	1607	1776
Centerline to Bottom	D	150F	241	298	318	354	419	435	499	603
Lay Length	A	300F	737	956	1108	1184	1327	1607	-	-
Centerline to Bottom	D	300F	260	324	356	387	457	499	-	-
<b>Angle Dimensions</b>										
Center Inlet to Discharge	B	FNPT	-	-	-	-	-	-	-	-
Center Discharge to Inlet	F	FNPT	-	-	-	-	-	-	-	-
Center Inlet to Discharge	B	150F	-	-	-	-	-	-	-	-
Center Discharge to Inlet	F	150F	-	-	-	-	-	-	-	-
Center Inlet to Discharge	B	300F	-	-	-	-	-	-	-	-
Center Discharge to Inlet	F	300F	-	-	-	-	-	-	-	-
<b>Common Dimensions (Globe and Angle)</b>										
Width	C		562	660	795	800	914	914	1264	1264
Height (To Stem Cap) Globe	E		592	679	797	797	797	875	1162	1162
Height (To Stem Cap) Angle	E		-	-	-	-	-	-	-	-
Body Port Tapping	FNPT	Inches	3/4	3/4	3/4	3/4	3/4	3/4	3/4	3/4
Stem Cap Plug	MNPT	Inches	3/4	3/4	3/4	3/4	3/4	3/4	3/4	3/4
Cover Port Tapping	FNPT	Inches	3/4	3/4	3/4	3/4	3/4	3/4	3/4	3/4
Valve Stroke		mm	83	83	120	120	120	143	150	150
Displaced Bonnet Volume (Litres)			5.67	8.69	25.52	25.52	25.52	44.41	55.76	55.76
Approx. Shipping Weight (Kilograms)			408	635	1089	1179	1270	2041	2812	3175
<b>Capacities (L/s) Globe &amp; Angle</b>										
CV - Globe			37.2	52.8	79.2	81.6	84.0	147.7	187	192
CV - Angle			-	-	-	-	-	-	-	-
Continuous (Globe)			404	582	1041	1041	1041	1098	2120	2132
Intermittent (Globe)			465	661	1320	1320	1320	1369	2362	2375
Momentary (Globe)			833	1211	1893	1896	1899	2461	4255	4267
<b>Maximum Pressure Ratings</b>										
Bar	FNPT		-	-	-	-	-	-	-	-
Bar	150F		17	17	17	17	17	17	17	17
Bar*	300F		27.5	27.5	27.5	27.5	27.5	27.5	27.5	27.5
* Valves rated and stamped 27.5 Bar as standard. Valves rated and stamped 41 Bar on request.										
<b>Maximum Temperature</b>										
Celcius			82°	82°	82°	82°	82°	82°	82°	82°

**NOTES:**

- Castings are based on ANSI Class 150 or Class 300 standards.
- ANSI Flanges drilled to ISO 2531/BS54504 PN 10, 16, 25, or 40, or threaded BSPT.
- Consult the factory if working pressure exceeds 20 Bar

Add a minimum 6" (150mm) on one side, for **Pilot System**. Pilot system is installed as "standard" ("opposite" please specify). Dimensions are nominal. Allow 1/8" (3mm) for machining tolerance. Allow one to three feet for installation and maintenance clearances. Consult factory for certified dimensions. Install with stem vertical is preferred. 10" (250mm) and larger is mandatory.

Main Valves

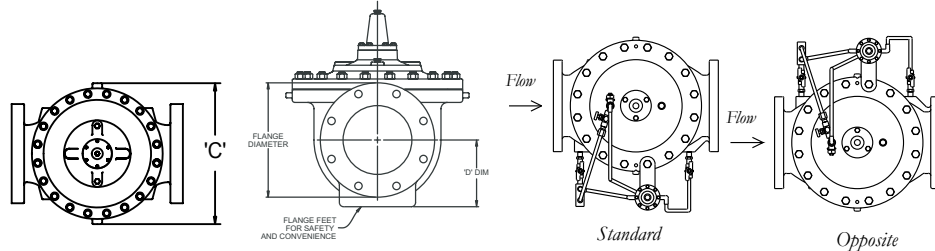
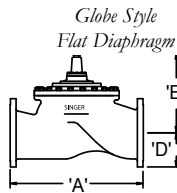

See Pilot System Information Below

ISO Valve Data (Metric Units) / see following page for additional data:

Size	DWG	Standard	Flat Diaphragm System				
MM	REF	ISO	80	100	150	200	250
		<b>BS4504</b>	<b>All figures show in mm unless otherwise stated</b>				
<b>Globe Dimensions</b>							
Lay Length	A	BSPT	-	-	-	-	-
Centerline to Bottom	D	BSPT	-	-	-	-	-
Lay Length	A	PN10/PN16	305	381	511	635	622
Centerline to Bottom	D	PN10/PN16	102	117	142	171	203
Lay Length	A	PN25/PN40	-	397	533	660	657
Centerline to Bottom	D	PN25/PN40	-	127	161	191	219
<b>Angle Dimensions</b>							
Center Inlet to Discharge	B	BSPT	-	-	-	-	-
Center Discharge to Inlet	F	BSPT	-	-	-	-	-
Center Inlet to Discharge	B	PN-10/16	-	192	259	318	-
Center Discharge to Inlet	F	PN-10/16	-	151	157	229	-
Center Inlet to Discharge	B	PN-25/40	-	200	270	330	-
Center Discharge to Inlet	F	PN-25/40	-	159	173	241	-
<b>Common Dimensions (Globe and Angle)</b>							
Width	C		208	238	318	406	508
Height (To Stem Cap) Globe	E		191	244	267	359	473
Height (To Stem Cap) Angle	E		-	197	224	287	-
Body Port Tapping	FNPT	Inches	3/8	3/8	3/8	3/8	1/2
Stem Cap Plug	MNPT	Inches	3/8	3/8	3/8	3/8	3/8
Cover Port Tapping	FNPT	Inches	3/8	3/8	3/8	1/2	1/2
Valve Stroke		mm	14	29	37	43	73
Displaced Bonnet Volume (Litres)			0.08	0.34	0.76	2.12	6.31
Approx. Shipping Weight (Kilograms)			34	45	113	227	295
<b>Capacities (L/s) Globe &amp; Angle</b>							
CV - Globe			1.4	3.6	6.0	12.1	23.6
CV - Angle			-	3.6	5.9	13.3	-
Continuous (Globe)			19	37	65	145	259
Intermittent (Globe)			24	44	75	170	295
Momentary (Globe)			36	78	136	303	530
<b>Maximum Pressure Ratings</b>							
Bar		BSPT	-	-	-	-	-
Bar		PN16	16	16	16	16	16
Bar		PN25	25	25	25	25	25
<b>Maximum Temperature</b>							
Celcius			82°	82°	82°	82°	82°

**NOTES:**

- Castings are based on ANSI Class 150 or Class 300 standards.
- Ansi Flanges drilled to ISO 2531/BS54504 PN 10, 16, 25, or 40, or threaded BSPT.
- Consult the factory if working pressure exceeds 20 Bar

Add a minimum 6" (150mm) on one side, for **Pilot System**. Pilot system is installed as "standard" ("opposite" please specify). Dimensions are nominal. Allow 1/8" (3mm) for machining tolerance. Allow one to three feet for installation and maintenance clearances. Consult factory for certified dimensions. Install with stem vertical is preferred. 10" (250mm) and larger is mandatory.

Angle Style  
Rolling Diaphragm

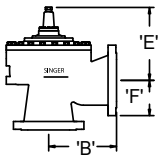

Globe Style  
Rolling Diaphragm

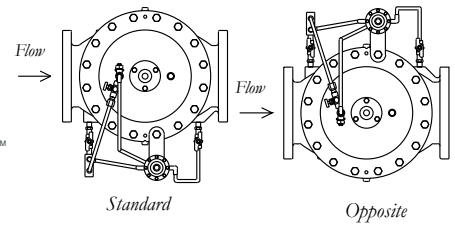
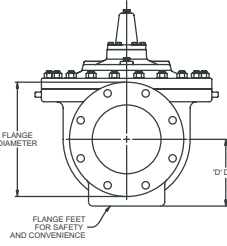
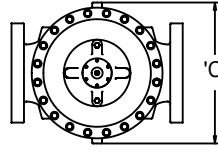
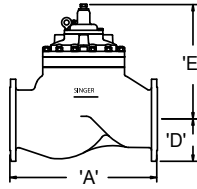

See Pilot System Information Below

## ISO Valve Data (Metric Units) / see previous page for additional data:

Size	DWG	Standard	Rolling Diaphragm System									
			300	400	450	500	600 x 400	600 x 500	700	800	900	
MM	REF	ISO										
		BS4504	All figures shown in mm unless otherwise stated.									
<b>Globe Dimensions</b>												
Lay Length	A	BSPT	-	-	-	-	-	-	-	-	-	-
Centerline to Bottom	D	BSPT	-	-	-	-	-	-	-	-	-	-
Lay Length	A	PN10/PN16	699	914	1067	1143	1283	1562	1607	1776	1776	
Centerline to Bottom	D	PN10/PN16	241	298	318	354	419	435	499	526	603	
Lay Length	A	PN25/PN40	699	956	1108	1184	1327	1607	-	-	-	
Centerline to Bottom	D	PN25/PN40	241	324	356	387	457	499	-	-	-	
<b>Angle Dimensions</b>												
Center Inlet to Discharge	B	BSPT	-	-	-	-	-	-	-	-	-	-
Center Discharge to Inlet	F	BSPT	-	-	-	-	-	-	-	-	-	-
Center Inlet to Discharge	B	PN-10/16	-	-	-	-	-	-	-	-	-	-
Center Discharge to Inlet	F	PN-10/16	-	-	-	-	-	-	-	-	-	-
Center Inlet to Discharge	B	PN-25/40	-	-	-	-	-	-	-	-	-	-
Center Discharge to Inlet	F	PN-25/40	-	-	-	-	-	-	-	-	-	-
<b>Common Dimensions (Globe and Angle)</b>												
Width	C		562	660	800	775	914	914	1262	1262	1262	
Height (To Stem Cap) Globe	E		592	679	797	797	797	875	1162	1162	1162	
Height (To Stem Cap) Angle	E		-	-	-	-	-	-	-	-	-	
Body Port Tapping	FNPT	Inches	3/4	3/4	3/4	3/4	3/4	3/4	3/4	3/4	3/4	3/4
Stem Cap Plug	MNPT	Inches	3/4	3/4	3/4	3/4	3/4	3/4	3/4	3/4	3/4	3/4
Cover Port Tapping	FNPT	Inches	3/4	3/4	3/4	3/4	3/4	3/4	3/4	3/4	3/4	3/4
Valve Stroke		mm	83	83	120	120	120	143	150	150	150	
Displaced Bonnet Volume (Litres)			5.67	8.69	25.52	25.52	25.52	44.41	55.76	55.76	55.76	
Approx. Shipping Weight (Kilograms)			408	635	1089	1179	1270	2041	2721	2993	3175	
<b>Capacities (L/s) Globe &amp; Angle</b>												
CV - Globe			37.2	52.8	79.2	81.6	84	147.7	187	190	192	
CV - Angle			-	-	-	-	-	-	-	-	-	
Continuous (Globe)			404	582	1041	1041	1041	1098	2120	2126	2132	
Intermittent (Globe)			465	661	1320	1320	1320	1369	2362	2368	2375	
Momentary (Globe)			833	1211	1893	1896	1899	2461	4255	4261	4267	
<b>Maximum Pressure Ratings</b>												
Bar		BSPT	-	-	-	-	-	-	-	-	-	-
Bar		PN16	16	16	16	16	16	16	16	16	16	16
Bar		PN25	25	25	25	25	25	25	25	25	25	25
<b>Maximum Temperature</b>												
Celcius			82°	82°	82°	82°	82°	82°	82°	82°	82°	82°

**NOTES:**

- Castings are based on ANSI Class 150 or Class 300 standards.
- ANSI Flanges drilled to ISO 2531/BS54504 PN 10, 16, 25, or 40, or threaded BSPT.
- Consult the factory if working pressure exceeds 20 Bar

Add a minimum 6" (150mm) on one side, for Pilot System. Pilot system is installed as "standard" ("opposite" please specify). Dimensions are nominal. Allow 1/8" (3mm) for machining tolerance. Allow one to three feet for installation and maintenance clearances. Consult factory for certified dimensions. Install with stem vertical is preferred. 10" (250mm) and larger is mandatory.

## AVAILABLE OPTIONS

### VALVE POSITION INDICATORS

- Model X107 stem mounted position indicators
- Model X129 limit switch assembly with S.P.D.T. limit switch
- Model X136M/X156 analog position transmitters (4 to 20 mA)

All of which may be installed at the factory or as a field modification.

**MATERIALS OF CONSTRUCTION** for individual components can be upgraded from ductile iron, bronze and brass to stainless steel, for most sizes. Consult with the factory.

**OXY NITRIDE STEM** provides extra protection against mineral deposits. See Main Valve Options Section.

**INTERNAL DROP CHECK** option provides a built-in, drop check to mechanically prevent reverse flow. See Main Valve Options Section.

**INTERNAL NEEDLE STEM VALVE** provides a restriction in the pilot circuit that is proportional to valve lift . See Pilots & Accessories Section.

**EXTERNAL SPRING LIFT** See Main Valve Options Section.

**MODEL PGM** provides a fully operational back-up system in the event of a diaphragm or pilot failure. See High Performance Section.

**GROOVED ENDS**—See Main Valve Options Section.

**RECLAIM WATER**—For Grey and Reclaim Water applications. See Main Valve Options Section.

**PILOTS & ACCESSORIES**—Singer Valve offers a wide range of Pilots & Accessories. See Pilots & Accessories Section.

## SELECTION

Automatic control valves operate by introducing or exhausting water from above the diaphragm at controlled rates. A pressure differential is required and is either inlet to outlet or inlet to atmosphere, depending on the application. Valves are sized to provide an appropriate pressure drop for each application. Consult the factory if the application does not have a minimum 5 psi (0.34 bar) to atmosphere or 10 psi (.68 bar) differential between inlet and outlet pressure.

Singer control valves are designed for use with clean potable water. Applications for other media are possible. Consult with the factory.

Careful consideration of the possibility of cavitation must be given. Anti-cavitation trim is available to control the cavitation, reduce noise and prevent damage. Refer to model 106- / 206\*(-)-AC (\*limited sizes) in the High Performance Section and consult with the factory.

The Singer model 206-PG single chambered valve is the basic valve used in practically every model bearing the 206 description. The pilot systems are designed to meet the functional and performance requirements of specific applications. Sizing is ultimately determined by the specific application.

## SPECIFICATIONS

- Valve(s) shall be a hydraulically operated globe (angle) valve. The inner valve assembly shall be top and bottom guided by means of easily replaceable bearing bushings. The inner valve assembly shall be the only moving part and shall be securely mounted on a 316 stainless steel stem. The stainless steel stem shall be provided with wrench flats on all valves 3” (80mm) to 16” (400mm), for ease of assembly and maintenance.
- All pressure containing components shall be constructed of ASTM A536-65/45/12 ductile iron. The flanges shall be designed to ANSI Class 150 or Class 300 standards. Flange drilling to ANSI shall be standard however British, ISO and other drillings shall be available upon request.
- Valve(s) shall have a protective fusion bonded epoxy coating internally and externally. The protective fusion bonded epoxy coating shall conform to the ANSI/AWWA C116/A21.16 (current version) specification.
- Valve(s) 10” (250mm) and smaller shall provide smooth “frictionless” motion with actuation being achieved by the use of a flat style BUNA / EPDM diaphragm. They shall be constructed of nylon fabric bonded with synthetic rubber. The diaphragms shall not be used as a seating surface. No lip seals or packing may be used to seal the actuator.
- Valve(s) 12” (300mm) and larger shall provide smooth “frictionless” motion and maximum low flow stability with actuation being achieved by the use of the Singer rolling diaphragm technology. The diaphragms shall not be used as a seating surface. No lip seals or packing may be used to seal the actuator.
- The valve cover shall have a separate stem cap giving access to the stem for alignment check, spring installation and ease of assembly.
- Bonnets shall be accurately located to bodies utilizing locating pins. Locating pins shall eliminate corrosion resulting from the use of uncoated ductile iron to ductile iron surfaces.
- The 316 stainless steel seat shall be bolted in place, utilizing “Spiralock” thread tapping technology. The 316 stainless steel seat ring shall be easily replaceable without special tools.
- The valve(s) shall form a drip tight seal between the stationary stainless steel seat ring and the resilient disc, which has a rectangular cross-section and is retained by clamping on three and one half sides. The resilient disc shall be constructed of Buna or EPDM for normal service conditions.
- All external fasteners shall be 18/8 stainless steel with 18/8 washers.
- All repairs and maintenance shall be possible without removing the valve from the line. To facilitate easy removal and replacement of the inner valve assembly and to reduce unnecessary wear on the guide, the stem shall be vertical when the valve is mounted in a horizontal line.
- Each valve shall be tested prior to shipment. The standard test shall include a pressure test and a full functional, operational test when pilots and accessories are fitted to suit a particular application.
- The valve(s) shall be covered by a minimum three year (3) warranty against defects in materials and workmanship. The stainless steel seat ring shall be covered by a lifetime replacement warranty.
- The valve shall be a Singer Model.... Refer to other Catalog Sections for further details.

Singer Valve Inc. • 12850 - 87th Avenue • Surrey, British Columbia, Canada V3W 3H9

Tel: 604 594 5404 • Fax: 604 594 8845

E-Mail: [singer@singervalve.com](mailto:singer@singervalve.com) • [singervalve.com](http://singervalve.com) • An ISO 9001:2000 Registered Company